



Instruction manual



Electric fryer 0,8 kW/l, 17 l on cabinet
400 V
FE 70/40 E

OBSAH

1. DECLARATION OF CONFORMITY	3
2. TECHNICAL DATA	3
3. GAS TABLE FOR WHICH THE PRODUCT IS INTENDED FOR	3
4. LOCATION	5
5. LOCATION	5
6. SAFETY MEASURES FOR FIRE PROTECTION	5
7. INSTALLATION	6
8. NÁVOD NA PROVEDENÍ ODTAHU PLYNU	7
9. THERMAL OUTPUT CHECK	7
10. CONNECTING GAS CONNECTION HOSE	7
11. LIQUID GAS CONNECTION	8
12. WATER CONNECTION	8
13. CONNECTING THE ELECTRICAL CABLE TO THE NETWORK	8
14. CHECK DEVICE SETTINGS FOR GAS TYPE	8
15. NÁVOD K POUŽITÍ	9
16. CLEANING AND MAINTENANCE	10
17. ODSTRAŇOVÁNÍ ZÁVAD	10
18. WIRING DIAGRAM	11

1. DECLARATION OF CONFORMITY

Decree of the Ministry of Health of the Czech Republic no. 38/2001 Coll. of 19 January 2001 Regulation (EC) No 1907/2006 - Registration, Evaluation, Authorisation and Restriction of Chemicals (REACH) Regulation of the European Parliament and Council Regulation (EC) no. 1935/2004 of 27 October 2004

The products meet the requirements of §26 of Act No.258/2000 as amended. The products meet the requirements of RoHS Directive 2015/863/EU, 10/2011, 517/2014, 2015/1094, 2015/1095.

Attention, the manufacturer gives up any responsibility in case of direct and indirect damage that is relate to poor installation, incorrect intervention or adjustments, insufficient maintenance, incorrect by using and which are eventually caused by other causes that the points referred to in the conditions sales. This appliance is intended only for professional use and must be operated by qualified by persons. Parts that have been secured by the manufacturer or authorized worker after the setting rebuild.

2. TECHNICAL DATA

The label with technical data is located on the side or back panel of the device. Please read the wiring diagram and all the following information in the attached manual before installation.

Net Width [mm]	Net Depth [mm]	Net Height [mm]	Net Weight [kg]
400	900	900	45.00
Power electric [kW]	Loading	Basin volume [l]	Ratio power/volume [kW/l]
13.500	400 V / 3N - 50 Hz	17	0.80

Maximum and reduced the rated heat input in kw is related to the HI used gas. If the product is connected to LPG, there must be a gas bottle in sufficiently ventilated rooms.

3. GAS TABLE FOR WHICH THE PRODUCT IS INTENDED FOR

version product category Connecting overpressure (mbar)

gas used Country of Determination

a1

i2e

20

G20

de, nl, pl, ro

a1

i2ell

20, 20

G20, G25

de

a1

i2e+

20/25

G20/G25

Be, FR

a1

i2H

20

G20

AT, BG, CH, CZ, DK, HR, EE, ES, FI, GB, GR, IE, IT, LT, LV, NO, PT, RO, SE, SI, SK, TR, LU, CY , Fr

a1

i3b/p

30

G30

BG, CY, CZ, DK, GB, HR, EE, FI, FR, GR, HU, IT, LT, LV, MT, NL, NO, RO, SE, SI, SK, TR

a1

i3b/p

50

G30

AT, DE, CZ, CH, FR, SK

a1

i3p

37

G31

be, ch, cz, es, gb, gr, ie, ro, si, SK, fr, nl, pt, hr, it, lt, pl, tr

a1

i3+

28-30/37

G30/G31

be, ch, cy, cz, ee, es, fr, gb, gr, ie, it, lt, pt, si, SK, tr

a1

II2E3B/P

20, 50

G20, G30

de, pl, ro

a1

II2ELL3B/P

20, 20, 50

G20, G25, G30

de

a1

II2E+3+

20/25, 28-30/37

G20/G25, G30/G31

Be, FR

a1

II2H3B/P

20, 30

G20, G30

BG, CZ, GB, DK, HR, EE, FI, GR, IT, LT, LV, NO, RO, SE, SI, SK, TR, CY, FR

a1

II2H3B/P

20, 50

G20, G30

AT, CH, CZ, FR, SK

a1

I12H3P

20, 37

G20, G31

CH, CZ, ES, GB, GR, IE, RO, SI, SK

a1

I12H3+

20, 28-30/37

G20, G30/G31

CH, CY, CZ, EE, ES, GB, GR, IE, IT, LT, PT, SK, SI, TR

4. LOCATION

For the correct operation and placement of the appliance, it is necessary to observe the following all prescribed standards for the given market. Unpack the device and check that the device has not been damaged during transport. Place the device on a horizontal surface (maximum unevenness up to 2°). Small unevenness can be leveled with adjustable feet. If the device will be placed in such a way that it will be in contact with the walls of the furniture, these must withstand a temperature of up to 60°C. Installation, adjustment, commissioning must be performed by a qualified person who is authorized to perform such operations, according to applicable standards. The device can be installed separately or in series with devices of our production. A minimum distance of 10 cm from flammable materials must be observed. In this case, it is necessary to secure the appropriate modifications to ensure the thermal insulation of the combustible parts. The appliance must only be installed on a non-flammable surface or against a non-flammable wall. **Parts of the appliance provided by the manufacturer. or his representative, the worker performing the installation may not rebuild the product.**

5. LOCATION

For the correct activity and location of the appliance, it is necessary to observe all directives and standards of the country. Expand the device and check that the device has not been damaged during transport. Place the device on the horizontal surface (maximum inequality up to 2 °). Minor inequalities can be balanced with regulated legs. If the device is located in contact with the walls of the furniture, they must withstand temperatures up to 60 ° C. Installation, adjustment, commissioning must be carried out by a qualified person who is authorized for such acts, according to valid standards. The device can be installed separately or in a series with our production devices. It is necessary to follow a minimum distance of 10 cm from flammable materials. In this case, it is necessary to ensure the appropriate adjustments to ensure the thermal insulation of flammable parts. The appliance must only be installed on a non -flammable surface or at a non -flammable wall. **The smallest required air flow from the outdoor space for appliances in design and in the range of 5-20 m3/h, depending on the type of appliance. It depends on the installation regulations for the country of destination. Components of the appliance secured by the manufacturer. Or his representative must not rebuild the worker's installation of the product. The device must be installed in a suitably ventilated environment.**

6. SAFETY MEASURES FOR FIRE PROTECTION

- the appliance may only be operated by adults
- the appliance may be used safely in accordance with applicable market standards:

Fire protection in spaces with special risk or danger

Protection against the effects of heat

- the appliance must be placed so that it stands or hangs firmly on a non-combustible surface

Objects of flammable substances must not be placed on the appliance at a distance less than a safe distance

ce from it (the smallest distance between the appliance and flammable substances is 10 cm).

Table: degree of flammability of building materials included in st. flammability of substances and products

Degree of flammability	Building materials
A - non-flammable	granite, sandstone, concrete, brick, ceramic tiles, plaster
B - Not easily flammable	Acumin, Heraclitus, Lihnos, Itaver
C1 - highly flammable	wood, hardwood, plywood, hard paper, umakart
C2 - moderately flammable	chipboards, solodur, cork boards, rubber, flooring
C3 - Highly flammable	wood fiber boards, polystyrene, polyurethane, PVC

- information on the degree of flammability of common building materials is given in the table above. Appliances must be installed in a safe manner. During installation, the relevant design, safety and hygiene regulations must also be respected:
- fire safety of local appliances and heat sources
- fire protection in areas with special risk or danger
- protection against the effects of heat

7. INSTALLATION

Important: The manufacturer does not provide any warranty for defects arising as a result of incorrect use, failure to follow the instructions contained in the attached user manual and mishandling of appliances. Installation, modification and repair of appliances for large kitchens, as well as their dismantling due to possible damage to the gas supply, can only be carried out on the basis of a maintenance contract, this contract can be concluded with an authorized dealer, while technical regulations and standards and regulations must be observed regarding installation, electrical supply, gas connection and work safety. Technical instructions for installation and adjustment, for use by specialized technicians ONLY. The instructions that follow refer to a technician qualified for installation to carry out all operations in the most correct manner and according to the applicable standards. Any activity related to regulation etc. must only be performed with the device disconnected from the network. If it is necessary to keep the appliance under voltage, the utmost care must be taken. The type of appliance for extraction is declared on the nameplate, it is an A1 appliance.

8. NÁVOD NA PROVEDENÍ ODTAHU PLYNU

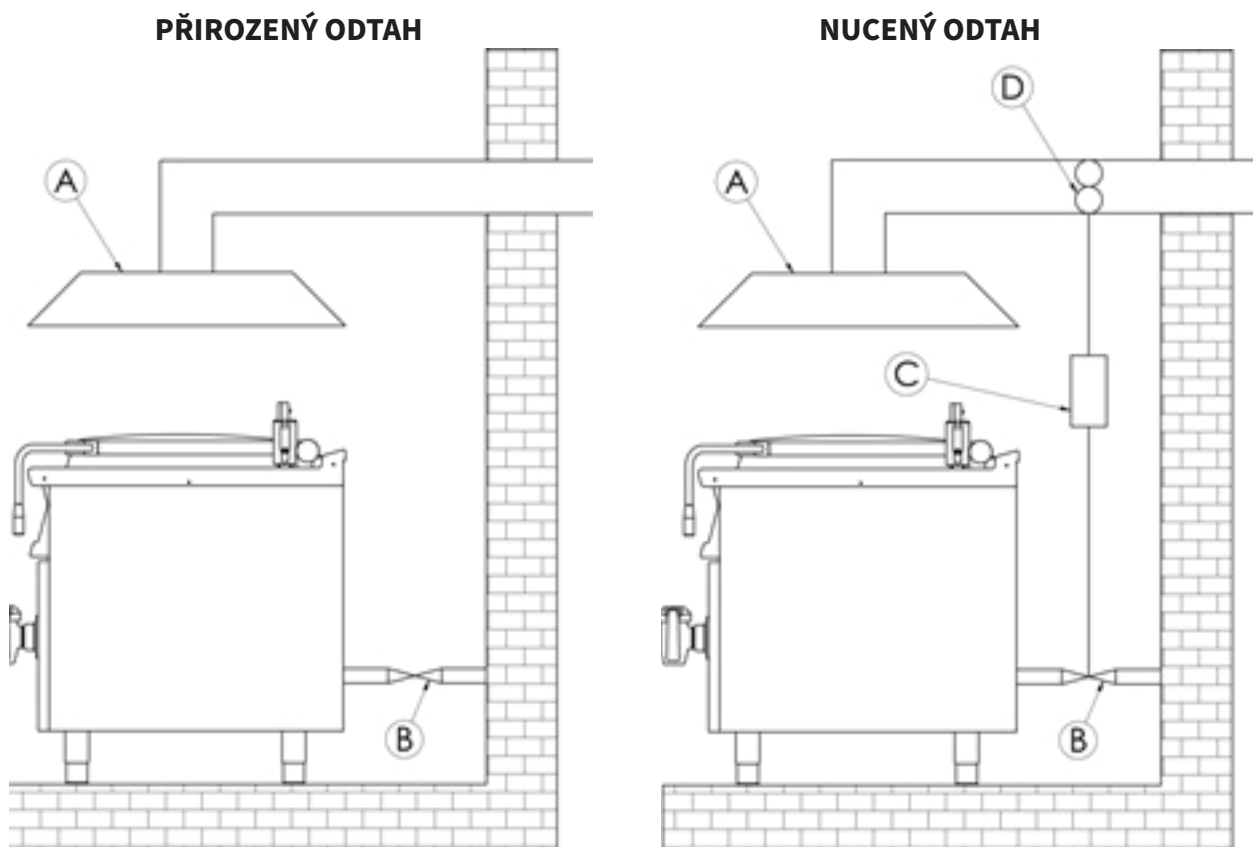

Vyústění digestoře je do samostatného komínového tělesa (A). Odtah spalin zabezpečuje přirozený tah komínu.

Vyústění digestoře je bez přirozeného odtahu. Odtah spalin je zabezpečován pomocí ventilátoru (D), (nucený odtah). V tomto případě je nezbytné zabezpečit propojení s přívodem plynu (B) pro vypnutí přívodu plynu při výpadku.

9. THERMAL OUTPUT CHECK

appliances must be checked to verify their thermal power input: The heat output is marked on the label or can be found in this manual. It is necessary to verify first if the appliance is made for the same type of gas to be used and therefore If the label corresponds to the gas type label to be used. To convert to another type of gas, it is necessary to check if the type of gas marked corresponds which is recommended in this manual. The pressure is measured by the pressure gauge of the necessary sensitivity. The pressure gauge is connected to the appropriate location, so it is necessary to unscrew the screw with an airtight cap and connect the pressure gauge. After the measurement, it is necessary to screw the screw back and check its tightness.

10. CONNECTING GAS CONNECTION HOSE

The gas must be connected by a tube with a maximum length of 1.5 meters of galvanized steel, copper or flexible steel hose in accordance with the applicable ground standards. Each device must have a closable tap at the inlet to easily stop the gas supply. After installing the device, we must check any gas leaks. Never check the leaks with an open fire. Materials that do not cause corrosion, for example, a soap water solution, must be used to check gas leakage. The devices underwent a thorough inspection of the manufacturer, the data on the type of gas, pressure and type of the device are listed on the label with characteristics. LPG bottles must be equipped with a controller that corresponds to the gas pressure on the equipment label in accordance with the applicable country's legislation.

11. LIQUID GAS CONNECTION

Connecting the appliance to the gas distribution system must be made by a steel or copper hose suitable for valid national requirements. This must be checked regularly and replaced as needed. Each appliance must be equipped with a closing tap and a quick slip. The quick slip must be freely accessible and within range of the device. After the installation, it is necessary to check that there is no gas leakage. To determine leaks we use soapy water or detection sprays to determine possible leaks. Do not use corrosion-causing substances! All our appliances are carefully inspected. The type of gas, pressure and designation of the relevant category are listed on the production label. Connection to liquid gas: The pressure for liquid gas connection must be 28 or 30 mbar for propane/butane and 37 mbar for propane. It is necessary to check the label, measure the pressure and check the parameters of the installed nozzles with the required nozzle parameters according to the manufacturer's requirements. If the pressure is less than 25 mbar or greater than 37 mbar must not be connected to the appliance. Natural gas connection: The pressure when connecting to methane must be 18 or 20 mbar. It is necessary to check the label, measure the pressure and check the parameters of the installed nozzles with the required nozzle parameters according to the manufacturer's requirements. If the pressure is less than 15 mbar or higher than 22.5 mbar must not be connected to the appliance.

12. WATER CONNECTION

Water connection is done using G1/2 threaded hoses. The water supply must be fitted with separate closures that are freely accessible and within reach of the device. The device includes return valves. The water pressure must be in the range of 50-300 kpa.

13. CONNECTING THE ELECTRICAL CABLE TO THE NETWORK

Installation of the electrical supply - this supply must be separately secured. Ato with the corresponding circuit breaker of rated current depending on the power input of the installed device. Check the power consumption of the device on the production label on the back panel (or side) of the device. The connected ground wire must be longer than the other wires. Connect the device directly to the network, it is necessary to insert a switch between the device and the device with a minimum distance of 3 mm between the individual contacts, which corresponds to the applicable standards and load. The earth supply (yellow-green) must not be interrupted by this switch. Connect the device to the mains if the socket has adequate protection. In any case, the supply cable must be located so that it does not reach a temperature of 50 degrees higher than the environment at any point. Before the appliance is connected to the network, it is necessary to first make sure that:

- the supply circuit breaker and the internal distribution can withstand the current load of the appliance (see matrix label)
- the distribution board is equipped with effective grounding according to the standards of the relevant market and the conditions given by law
- the socket or switch in the supply is easily accessible from the appliance
- the electrical supply to the device must be made of oil-resistant material

We disclaim any responsibility in the event that these standards are not respected and in the event of a violation of the above principles. Before first use, you must clean the device, see chapter cleaning and maintenance. The appliance must be grounded using a screw with a grounding mark.

- Do not insert the plug of the power supply into the electrical outlet. sockets and do not pull out the zel. sockets with wet hands and pulling on the power cord!
- Do not use extension cords or multiple sockets.
- **The mains connection point must have a maximum of the following impedance: $Z_{MAX} = 0.042 + j 0.026 \Omega$ for the phase conductors and $0.028 + j 0.017 \Omega$ for the neutral conductor.**

14. CHECK DEVICE SETTINGS FOR GAS TYPE

Our appliances are certified and regulated for natural gas (see type plate). Conversion or adaptation to a

different type of gas must only be carried out by an authorized technician. Nozzles for different types of gas are in a bag packed with the boiler and are marked in hundredths of mm (technical data table).

15. NÁVOD K POUŽITÍ

Pozor! Než-li začnete přístroj používat, je nutné z celého povrchu sejmout ochranné fólie, a pak jej dobře omýt vodou se saponátem na nádobí, a poté otřít vlhkým hadrem.

Nikdy nenechte přístroj v chodu bez dozoru.

Nikdy nezapínejte přístroj bez oleje nebo pokud je hladina oleje pod ryskou minima existuje nebezpečí požáru. Pokud je olej znečištěn nebo jej používáte delší dobu hrozí překypění oleje.

Po připojení zařízení k síti se ujistěte, že topné těleso je v pracovní poloze (obr. 1). Pokud je topné těleso otočeno do svislé polohy, není možné zařízení uvést do provozu (obr. 2). Naplňte přístroj olejem vhodným ke fritování až po rysku maxima na boční straně. Zapněte hlavním vypínačem el. přívod, ovladačem (A) nastavte na vámi požadovanou hodnotu v rozpětí 50°C - 190°C. Kontrolky (B) a (C) budou svítit. Kontrolka (B) svítí, když je přístroj pod el. proudem. Kontrolka (C) svítí, pokud jsou v chodu tepelné spirály. Kontrolka (C) zhasne, když je přístroj nahřátý na nastavenou teplotu. Přístroj vypnete, otočením ovladače (A) do polohy „0“.

Popis ovládacího panelu



- (A) Ovládací knoflík
- (B) Kontrolka chodu
- (C) Kontrolka vyhřátí

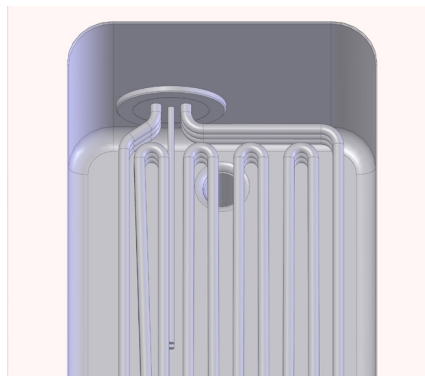
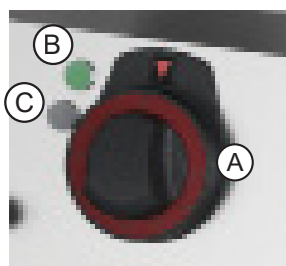
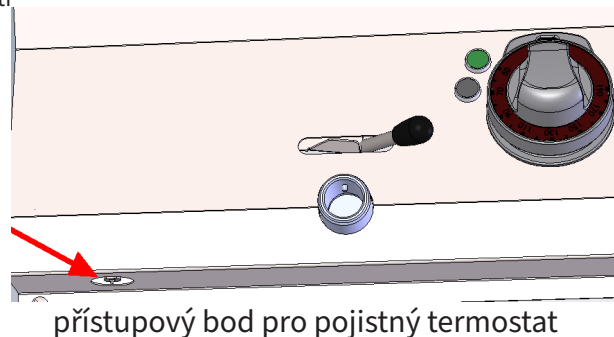

obr. 1



obr. 2

VYPUŠTĚNÍ VANY

Vanu vylévejte, pokud je olej chladný a přístroj je odpojen od elektrického proudu. Uživatel se musí vybavit

vhodnou nádobou na vypouštění oleje z vany. Tato nádoba musí být z tepelně odolného materiálu a musí být postavena tak, že olej nebude stříkat a tím nebude způsobovat nebezpečí. Nasaďte odtokovou trubicí odstraňte pojistku proti nechtěnému otevření směrem vzhůru a páčku posuňte do polohy s označením otevřeného kohoutu. Vanu vypouštějte, pokud je olej chladný.

U některých druhů fritéz se vypouští olej do nádoby umístěné v podestavbě. Otočte pákou do polohy s označením otevřeného kohoutu. Vanu vypouštějte, pokud je olej chladný.

Poznámky a doporučení

Neustále kontrolujte hladinu oleje, nikdy nepoužívejte přístroj bez oleje. Používejte přístroj pouze pod dohledem. Dolíváme olej maximálně po rysku GN, která označuje maximální množství. K překypění fritézy může dojít, pokud olej v gastronádobě obsahuje vodu.

16. CLEANING AND MAINTENANCE

It is recommended to have the device checked with a specialist service at least once a year. All interventions in the device can only be carried out by a qualified person who has the permission to act. **Caution!** The device must not be cleaned with direct or pressure water. Clean the equipment daily. Daily maintenance extends the life of the equipment and the equipment of the equipment. Always turn off the main KZA procurement. Wash the stainless steel parts with a damp cloth with a detergent without coarse particles. Do not use abrasive or corrosive cleaning agents. Attention! Before using the device, it is necessary to remove protective foils, and wash it well with water with detergent, wipe it with a damp cloth. **alert** The warranty does not apply to all consumables subject to normal wear (rubber seals, bulbs, glass and plastic parts, etc.). The warranty also does not apply to the device if the installation is not carried out in accordance with the instructions - an authorized worker according to the corresponding standards and if the equipment was unprofessionally manipulated (interventions in the internal equipment, etc.) or were operated by unhappy staff and contrary to the instructions for use, further The warranty does not apply to damage by natural effects or other external intervention. **Required service organization 2 times a year. After the lifetime, the shipping packaging and equipment are submitted to the collection, according to the regulations on waste management and hazardous waste.**

17. ODSTRAŇOVÁNÍ ZÁVAD

Závada	Možná příčina	Doporučené řešení
fritéza nehřeje	vypadlý pojistný termostat	pod předním panelem pod membránou zkuste zmáčknout, zda není vypdalý pojistný termostat. V případě že bude vypadávat opakovaně, nutno volat servis

Item number	Item description
402590710	Podložka regulačního knoflíku RF-900 mat
402590708	Regulační knoflík RF-900 mat E
402070000	Bužírka izolační 12mm
402511000	Termostat pojistný 235°C 1 fáz. FE
409081002	Těsnění ploché samolepící 10x2 mm
402080020	Svorka DIN modrá
402080031	Klema svorky DIN Q2
401515151	Kontrolka kulatá zelená LED L700
401515152	Kontrolka kulatá bílá LED L700
402594257	Samolep. etiketa se stupnicí FE-E L900 REDFOX

Item number	Item description
401520005	Mikrospínač L 700
408015053	Spínací kolík otočného tělesa
402503201	Spojka k termostatu pracovnímu 60-310°C BR
402502000	Termostat pracovní 50-190°C 1 fáz. FE
900001016	Podložka pod mikrospínač
401506000	Vypínač otočný k termostatu 60 - 310°C BR
409081211	Průchodka izolační s membránou SR 1705 - pro otvor pr. 25,5 - černé měkčené PVC
408001152	Hrazda závěsná FE

18. WIRING DIAGRAM

